



# Ministry of Education, Higher Education and Vocational Education

## Science Branch

Grade 11

Supportive Test - 2025 (2026)

34

E

I

Science I

One Hour

**Instructions:**

- Answer all questions.
- In each of the questions 1 to 40, pick one of the alternatives (1), (2), (3), (4) which you consider is correct or most appropriate. ( $g = 10 \text{ m s}^{-2}$ )

1. Which of the following is the correct statement regarding phloem tissue?
  - (1) transporting sucrose.
  - (2) transporting water.
  - (3) transporting water and glucose.
  - (4) transporting water and minerals.
2. What is the element that forms an ionic compound by combining with Chlorine?
  - (1) Be
  - (2) Al
  - (3) P
  - (4) Ca
3. Which of the following is a device that utilizes electromagnetic induction ?
  - (1) DC Motor.
  - (2) Electric bell.
  - (3) Loud speaker.
  - (4) Credit cards.
4. Which of the following is a method that **should NOT** be followed when writing the scientific name of an organism ?
  - (1) Writing it in two parts as the Generic name and the Specific epithet.
  - (2) Writing the first letter of both the generic name and the specific epithet in capital letters.
  - (3) Underlining the name when writing by hand.
  - (4) Using italics when printing.

5. The diagram shows an electrochemical cell. *X* and *Y* are two metals. What is the true statement regarding this cell?

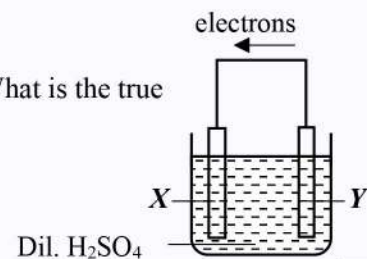

- (1) *X* undergoes oxidation.
  - (2) The pH value of the solution decreases with time.
  - (3) *Y* acts as the anode
  - (4) *X* is placed above *Y* in the reactivity series.
6. When a force  $F$  is applied to an object of mass  $M$  placed on a frictionless surface, it moves with an acceleration  $a$ . If another mass  $M$ , identical to the first, is placed on top of it and the same force  $F$  is applied, what will be the new acceleration of the object?



- (1)  $a/2$
  - (2)  $a$
  - (3)  $2a$
  - (4)  $4a$
7. A child screams in fear upon seeing a snake. A change that occurs within the child's body is,
  - (1) Contraction of pupil.
  - (2) Reduction of heart beat.
  - (3) Stimulation of peristalsis.
  - (4) Inhibition of salivary glands.
8. What is the number of hydrogen atoms contained in 30 g of Acetic acid ( $\text{CH}_3\text{COOH}$ ) ?  
( $\text{CH}_3\text{COOH} = 60$ )
  - (1)  $0.5 \times 6.022 \times 10^{23}$
  - (2)  $2 \times 6.022 \times 10^{23}$
  - (3)  $4 \times 6.022 \times 10^{23}$
  - (4)  $30 \times 6.022 \times 10^{23}$
9. Which option shows the compounds in the descending order of their pH values?
  - (1) HCl,  $\text{H}_2\text{CO}_3$ ,  $\text{NH}_4\text{OH}$ , NaOH
  - (2) HCl,  $\text{H}_2\text{CO}_3$ , NaOH,  $\text{NH}_4\text{OH}$
  - (3) NaOH,  $\text{NH}_4\text{OH}$ ,  $\text{H}_2\text{CO}_3$ , HCl
  - (4)  $\text{NH}_4\text{OH}$ , NaOH,  $\text{H}_2\text{CO}_3$ , HCl
10. The figure shows a circuit setup designed to demonstrate electromagnetic induction. When a bar magnet is continuously inserted into and withdrawn from the wire coil, the observations for LEDs  $L_1$  and  $L_2$  are,
  - (1) Glowing  $L_1$  only.
  - (2) Glowing  $L_2$  only.
  - (3) Continuously glowing the  $L_1$  and  $L_2$ .
  - (4) Glowing  $L_1$  and  $L_2$  vice versa.

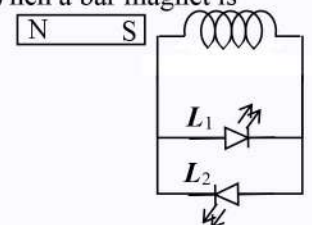

11. Which is the correct answer regarding the processes of respiration and photosynthesis occurring in plants?

|     | Respiration                         | Photosynthesis                      |
|-----|-------------------------------------|-------------------------------------|
| (1) | Occurs only during the night.       | Occurs only during the daytime.     |
| (2) | Occurs during both day and night.   | Occurs only when light is present.  |
| (3) | Glucose is produced.                | Glucose is consumed (used up).      |
| (4) | A process where energy is consumed. | A process where energy is produced. |

12. Three statements regarding the process occurring inside the blast furnace during the extraction of iron are given below.

- A - Iron is produced by the oxidation of Hematite.
- B - Limestone is used as a raw material to remove impurities present in the ore.
- C - Coke, which is fed into the blast furnace, also acts as a fuel.

Which of the above statements are true ?

- (1) A and B only.            (2) A and C only.            (3) B and C only.            (4) All A, B and C.

13. What is the function of the commutator in a direct current (DC) motor ?

- (1) To increase the strength of the magnetic field.
- (2) To convert direct current (DC) into alternating current (AC).
- (3) To reverse the direction of the current flowing through the armature.
- (4) To act as a support to hold the armature.

14. Processes related to several organs in the human body are shown in the figure. These organs are labeled as x, y, and z.

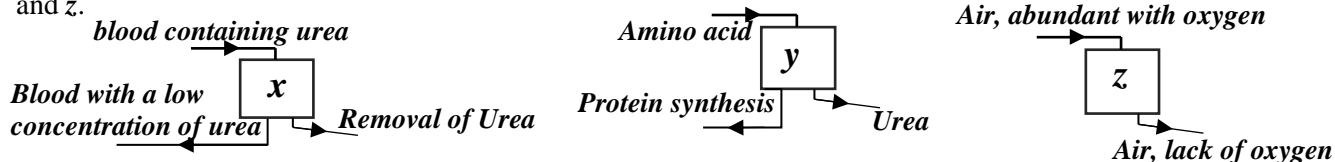

When organs x, y and z are named correctly in order, they are,

- (1) kidney, liver and lung.
- (2) liver, kidney and heart.
- (3) lung, liver and kidney.
- (4) Pancreas, lung and kidney.

15. Consider the following statements regarding hormones.

- A- Influences the phases of the menstrual cycle.
- B- Secreted by the pituitary gland.
- C- Stimulates the growth of primary follicles.

The true statements regarding FSH and LH among these are,

- (1) A and B only.    (2) A and C only.    (3) B and C only.    (4) All A, B and C.

16. Which of the following is a true statement regarding the reflection and refraction of a wave ?

- (1) In reflection, the velocity changes, but the amplitude does not change.
- (2) In refraction, the frequency does not change, but the velocity changes.
- (3) In reflection, the velocity changes, but the wavelength does not change.
- (4) In refraction, the frequency changes, but the wavelength does not change.

17. Which of the following is the correct energy level diagram for the thermal decomposition reaction of limestone?

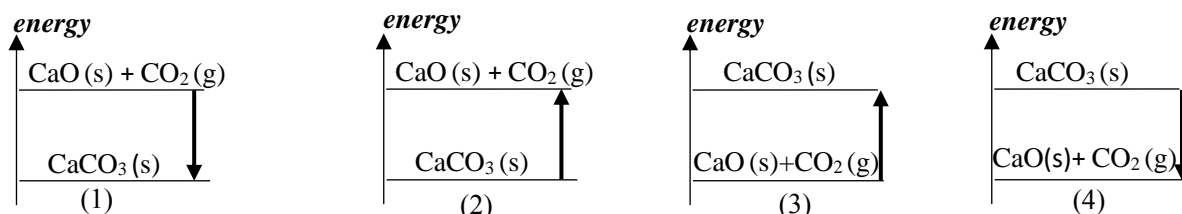

18. The figure shows how a rod is in equilibrium under three forces A, B, and C. Select the false statement from the following statements.

- (1) Resultant of A and B forces equal to C.
- (2) All A, B and C forces lie on same plane.
- (3) Sum of moment of forces caused by A, B and C, is zero.
- (4) The resultant of the two forces A and B acts in a direction located between those two forces.

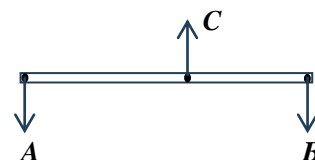

19. The figure shows a microscopic representation of a cross-section of a flowering plant stem capable of vegetative propagation. In relation to it, consider the statements **A**, **B**, **C**, and **D** in the table.

|          | Plant    | Vegetative propagation method |
|----------|----------|-------------------------------|
| <b>A</b> | Dicot.   | Grafting                      |
| <b>B</b> | Dicot    | Tissue culture                |
| <b>C</b> | Monocot. | Grafting                      |
| <b>D</b> | Monocot. | Tissue culture                |

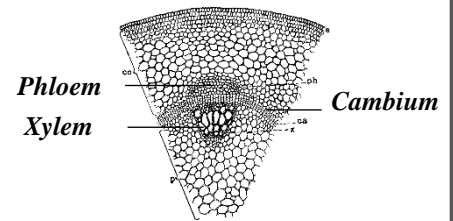

Which of these are correct?

- (1) **A** and **B** only.      (2) **A** and **C** only.      (3) **C** and **D** only.      (4) **A**, **B** and **D** only.

20. Consider the following statements regarding non-metals.

- A-** All non-metals do not conduct electricity.  
**B-** They contribute to the formation of both covalent and ionic compounds.  
**C-** They can exist in solid, liquid, and gaseous states at room temperature.

Which of the above statements are true ?

- (1) **A** and **B** only.      (2) **A** and **C** only.      (3) **B** and **C** only.      (4) All **A**, **B** and **C**.

21. Several diseases related to the circulatory system are given below.

- A-** coronary thrombosis      **B-** stroke      **C-** Atherosclerosis.

Out of those, the diseases caused by the condition shown in the diagram are,

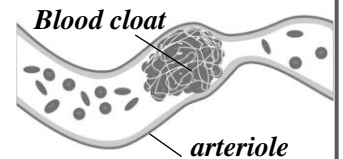

- (1) **A** and **B** only.      (2) **A** and **C** only.      (3) **B** and **C** only.      (4) All **A**, **B** and **C**.

22. What is the most effective measure to prevent metal corrosion when fixing steel hinges to an aluminum door?

- (1) Painting both metals thoroughly.      (2) Attaching small pieces of a less reactive metal to the door.  
 (3) Painting only the steel hinges.      (4) Inserting a rubber washer between the door and the hinges.

23. When a potential difference of 12 V is applied across the terminals **A** and **B** of the resistor system shown in the figure, what is the current flowing through resistor  $R_1$

- (1) 2 A      (2) 1.5 A  
 (3) 1 A      (4) 0.5 A

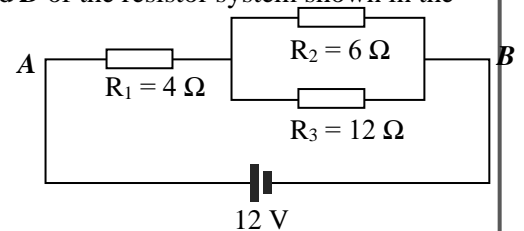

24. Three statements regarding a particle traveling at a uniform velocity are given below.

- A -** The resultant of all forces acting on the particle is zero.  
**B -** A resultant force acts in the direction in which the particle is moving.  
**C -** The particle has no acceleration.

Which of the above statements are true ?

- (1) **A** and **B** only.      (2) **A** and **C** only.      (3) **B** and **C** only.      (4) All **A**, **B** and **C**.
25. Electronic configuration of an atom of an element **X** is 2,8,6 . Which of the following is the ion formed by atom **X** ?
- (1)  $X^-$       (2)  $X^{2-}$       (3)  $X^{2+}$       (4)  $X^{6+}$

26. Study the pairs of events/incidents denoted by **A**, **B**, **C**, and **D** below.

|                       | <b>A</b>     | <b>B</b>   | <b>C</b> | <b>D</b> |
|-----------------------|--------------|------------|----------|----------|
| Hormone concentration | ADH          | Calcitonin | Glucagon | Insulin  |
| Variable Factor       | Urine volume | Calcium    | Glucose  | Glycogen |

Which answer represents the pairs of events where an increase in hormone concentration results in a decrease in the variable factor?

- (1) **A** and **B** only.      (2) **A** and **C** only.      (3) **A** and **D** only.      (4) **C** and **D** only.
27. A machine lifts an object with a mass of 200 kg to a height of 10 m at a uniform velocity of 2 m s<sup>-1</sup>. What is the power of the machine? ( $g = 10 \text{ m s}^{-2}$ )
- (1) 1000 J s<sup>-1</sup>      (2) 2000 J s<sup>-1</sup>      (3) 3000 J s<sup>-1</sup>      (4) 4000 J s<sup>-1</sup>

28. Three statements regarding the characteristics of catalysts are given below.

- A- Catalysts increase the amount of product formed at the end of the reaction.
- B- A small amount of catalyst is sufficient for a large amount of reactants.
- C- It does not undergo any chemical change at the end of the reaction.

Which of the above statements are true ?

- (1) A and B only.                      (2) A and C only.                      (3) B and C only.                      (4) All A, B and C.

29. The primary safety function of a Residual Current Circuit Breaker (RCCB) in a domestic electrical circuit is,

- (1) To protect a person from electric shock.
- (2) To prevent fires caused by electricity leaking from appliances.
- (3) To prevent damage caused by lightning accidents.
- (4) To prevent accidents caused by excessive current flowing through a socket circuit.

30. In a garden pea plant, red flower color is the dominant trait (R) and white flower color is the recessive trait (r). After crossing plants with red flowers and plants with white flowers, the resulting seeds were planted. Out of these, 596 plants with red flowers and 588 plants with white flowers were obtained. What could be the genotypes of the parents

- (1) RR,rr                                      (2) Rr,Rr                                      (3) Rr , rr                                      (4) rr, rr

31. In an experiment conducted on solubility, it was found that the solubility of a certain substance is 36 g at a temperature of 25°C. 40 g of this substance was added to 100 g of water, stirred well until the maximum amount of solute was dissolved, and then filtered using a filter paper. Finally, what is the nature of the resulting solution and the mass of the residue remaining on the filter paper respectively?

|     | Nature of solvent | mass (g) |
|-----|-------------------|----------|
| (1) | Unsaturated       | 4        |
| (2) | Saturated         | 4        |
| (3) | Unsaturated       | 0        |
| (4) | saturated         | 0        |

32. The figure shows a cross-section of a villi located in the small intestine. Which components of the end products of digestion travel into P and Q ?

|   | P           | Q           |
|---|-------------|-------------|
| 1 | Amino acids | Glycerol    |
| 2 | Glycerol    | Fatty acids |
| 3 | Fatty acids | Glucose     |
| 4 | Glucose     | Glycerol    |

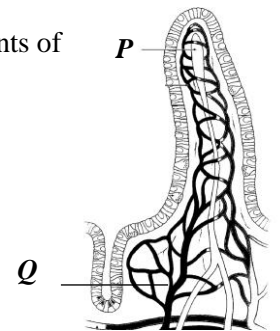

33. Consider the following statements

- A : Cultivating leguminous crops leads to the enrichment of soil fertility.
- B : Bacteria such as *Rhizobium*, living symbiotically inside root nodules, convert atmospheric nitrogen into ammonia.

- (1) Both A and B statements are correct.                                      (2) Statement A is correct. Statement B is incorrect  
 (3) Both A and B statements are incorrect.                                      (4) Statement B is correct. Statement A is incorrect

34. Given below is a table of results from experiments conducted to compare the reactivity of three metals. (A tick (✓) indicates that a reaction occurred, and a cross (✗) indicates that no reaction occurred.)

| Metal | With cold water | With hot water | With dil. Acids |
|-------|-----------------|----------------|-----------------|
| X     | ✓               | ✓              | ✓               |
| Y     | ✗               | ✗              | ✗               |
| Z     | ✗               | ✓              | ✓               |

Which answer represents the metals X, Y, and Z in descending order of their reactivity rate?

- (1) X, Y, Z                                      (2) X, Z, Y                                      (3) Y, X, Z                                      (4) Z, Y, X

35. Three students designed three crowns named A, B, and C using different non-absorbent materials for an exhibition. The masses of all three crowns are equal to each other, and the figure shows how they appeared when submerged in a water container.

Which of the following is the correct statement regarding this ?

- (1) The volumes of water displaced by all three crowns are equal to each other.
- (2) The submerged volumes of crowns A and B are equal
- (3) The volume of water displaced by B is greater than the volume of water displaced by A.
- (4) The weight of the water displaced by C must be greater than the weight of the crown.

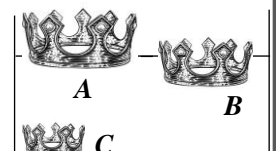

36. Three statements regarding the use of thermal radiation are given below.  
**A** - People in cold countries wear dark-colored clothes to keep their bodies warm.  
**B** - By making the inner surface of a vacuum flask shiny, chilled water can be kept cool for a longer time.  
**C** - New clay pots heat up faster than black-colored clay cooking pots placed on a stove.

From the statements above, the true statement(s) is/are ,

- (1) **A and B**                      (2) **B and C**                      (3) **A and C**                      (4) **All A,B and C.**

37. Several statements regarding the advantages of using convex mirrors as side mirrors in vehicles are given below.

**A** - Minimizing the reflection of light beams from vehicles coming from behind into the eye at night

**B** - Being able to see a large area at once in a smaller size (Wide field of view)

**C** - Being able to see the rear views upright (Erect).

The true statement(s) from these is/are,

- (1) **A and B**                      (2) **B and C**                      (3) **A and C**                      (4) **All A,B and C.**

38. The flow of components **X** and **Y** along a food chain was presented in a science magazine as follows.

|           |                  |   |                 |   |               |
|-----------|------------------|---|-----------------|---|---------------|
| component | Grass            | → | Deer            | → | Tiger         |
| <b>X</b>  | <b>120 000 J</b> |   | <b>12 000 J</b> |   | <b>1200 J</b> |
| <b>Y</b>  | <b>10 mg</b>     |   | <b>105 mg</b>   |   | <b>280 mg</b> |

Which answer contains the most likely components for **X** and **Y**

|   | <b>X</b>        | <b>Y</b>        |
|---|-----------------|-----------------|
| 1 | Organic matter. | Heavy metals.   |
| 2 | Energy.         | Organic matter. |
| 3 | Heavy metals.   | Organic matter. |
| 4 | Energy.         | Heavy metals.   |

39. What can be considered as the most practical solution to minimize the death of wild elephants in Sri Lanka caused by human activities?

- (1) Constructing new parks exclusively for wild elephants with all facilities to allow them to roam freely.  
 (2) Constructing strong elephant fences around large forests to prevent wild elephants from entering villages.  
 (3) Constructing wildlife bridges (overpasses/underpasses) across highways and railways that run through forests to allow elephants and other wildlife to cross safely.  
 (4) Donating elephants to countries with large forests in the world, as the elephant population in Sri Lanka is exceeding its carrying capacity.

40. Short-sighted human activities contribute to the occurrence of natural disasters. However, humans must successfully face the resulting disaster situations. Several ways to focus on this are given below.

**A**- Becoming aware of disaster management and relief services.

**B**-.Positively developing social emotions that arise after a disaster.

**C**- Improving mental health and uplifting the mental state of others.

As a student, the areas you should focus on are,

- (1) **A and B**                      (2) **B and C**                      (3) **A and C**                      (4) **All A,B and C.**

\*\*\*



**Ministry of Education, Higher education and Vocational education.  
Science Branch**

**Grade 11**

**Supportive Test - 2025 (2026)**

**34 E II**

**Science II**

**Three hrs.**

**Note:** This question paper consists of two parts, **A and B**.  
Answer **all** questions in **Part A** within the space provided.  
Answer **only three** questions in **Part B**.

**Part A- Structured Essay**

1. (A) Figures A and B represent a polar ecosystem and a mangrove ecosystem, respectively.

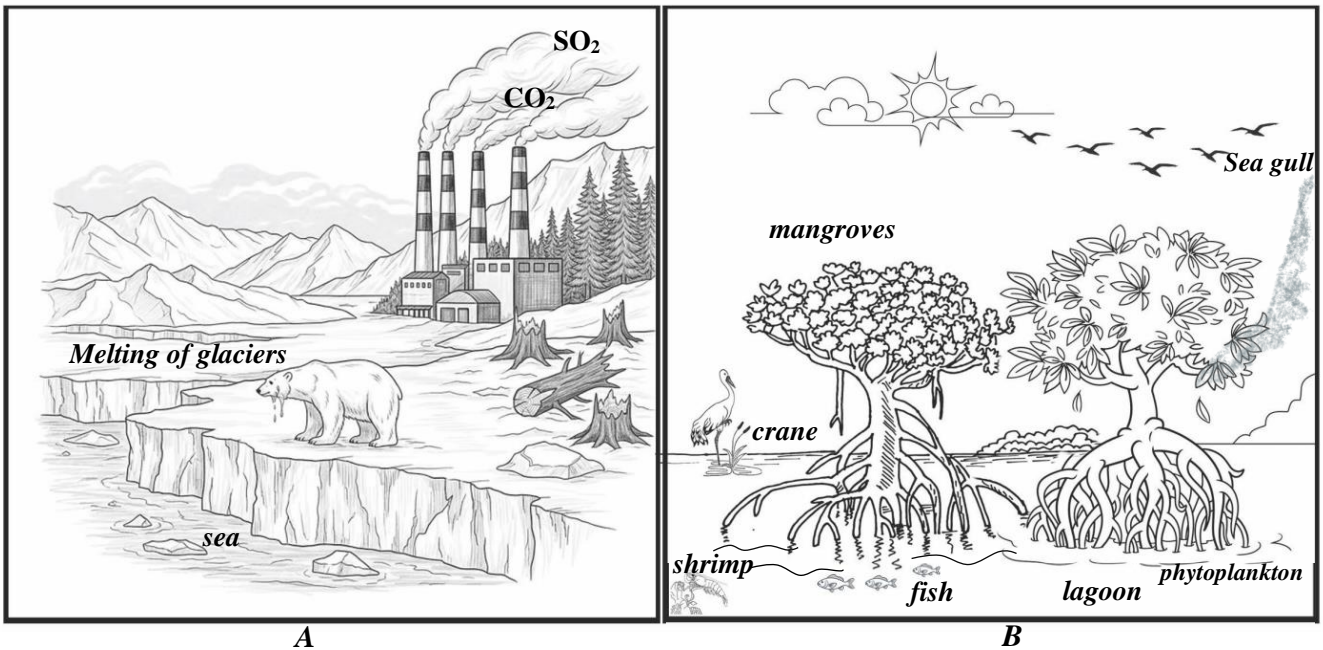

- (i) From the above ecosystems **A** and **B**,
  - (a) Which ecosystem has fallen victim to the adverse effects of air pollution? ..... (01)
  - (b) Which ecosystem possesses a high biodiversity? ..... (01)
- (ii) Complete the following table in relation to the changes that have occurred in the above ecosystem **A**. (04)

| Changes occurred in Ecosystem <b>A</b>                  | Related direct or indirect impact |
|---|-----------------------------------|
| Accumulation of <b>SO<sub>2</sub></b> in the atmosphere | (a) .....                         |
| Increase in <b>CO<sub>2</sub></b> concentration         | (b) .....                         |
| (c) .....   | Loss of habitats                  |
| (d) .....   | Rising the sea level              |

- (iii) Write down a three-link food chain found within ecosystem **B** .  
.....(01)
- (iv) Based on the diagram, name an adaptation shown by mangrove plants to remain stable within ecosystem **B**.  
.....(02)
- (v) It is reported that carbon absorption and storage in mangrove plants are highly efficient, and even after they die, carbon remain as residues between soil layers without decomposing for thousands of years. State how this phenomenon affects the Carbon Cycle.  
..... (01)

(B) The following bar chart displays data from an annual survey report on how dietary patterns and body mass conditions affect the number of deaths caused by Non-Communicable Diseases (NCDs).

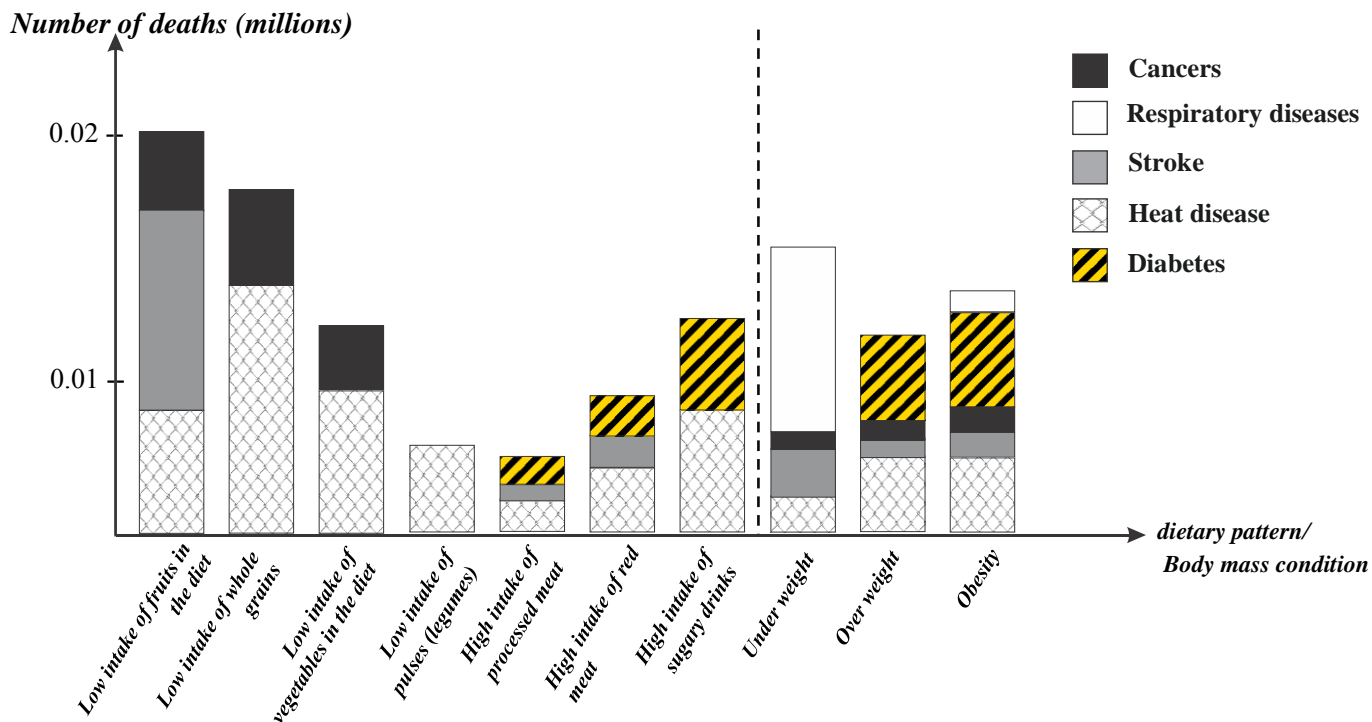

Based on the above bar chart, answer the following questions.

- Which disease causes the highest number of deaths annually? .....(01)
- What condition leads to the highest number of people falling victim to diseases? ..... (01)
- What is the main factor contributing to the increased risk of death due to respiratory diseases?  
..... (01)
- Which dietary pattern has the greatest impact on increasing the risk of death due to diabetes?  
..... (01)
- The mortality rate caused by which primary disease condition can be reduced by consuming fruits?  
..... (01)

15

2.(A) An experimental setup prepared by a student in the laboratory to confirm that oxygen gas is released during photosynthesis is shown here.

(i) State the reason why the student used the following materials for this activity. Write the reason in front of each. (02)

- Light bulbs - .....
- Glass funnel - .....

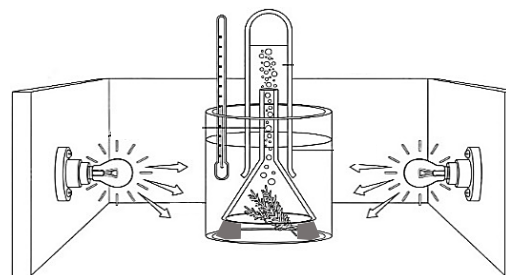

(ii) Shown here are five cards *a, b, c, d* and *e* used to construct the chemical equations of two biological processes occurring within green plants.

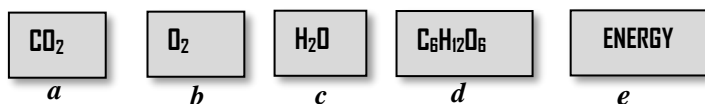

- Use the letters of the cards required to construct the photosynthesis equation in the relevant blanks.  
..... + .....  $\xrightarrow[\text{Chlorophyll}]{e}$  ..... + ..... (01)
- What is the other biological process that can be represented using the cards mentioned above?  
.....(01)

(B) Shown here are three leaflets containing characteristics of living organisms, classification levels, and the names of several organisms.

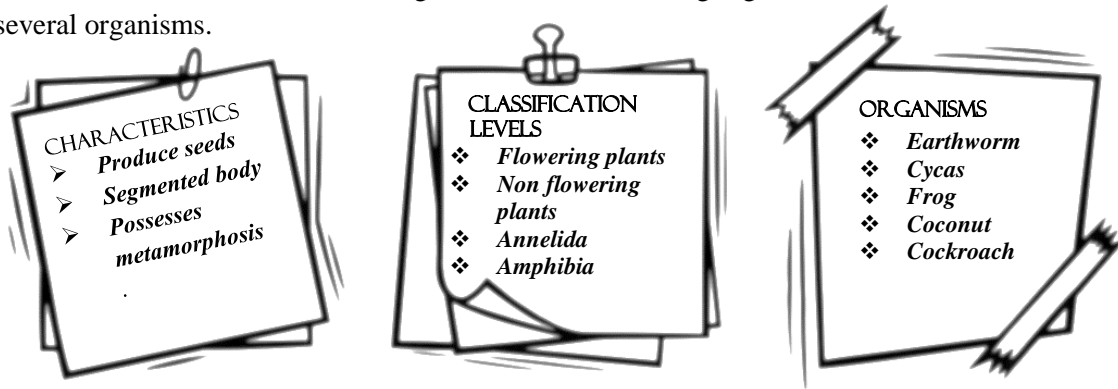

Complete the blanks (a), (b), (c), (d), and (e) by matching the information provided accordingly. (05)

| Characteristic           | Classification level | An organism as an example |
|--------------------------|----------------------|---------------------------|
| Possesses metamorphosis. | (a) .....            | (b) .....                 |
| The body is segmented.   | Annelida             | (c).....                  |
| (d).....                 | (e) .....            | Cycas                     |

(C) In an experiment conducted to demonstrate the action of the amylase enzyme on starch, a small amount of amylase solution was added to a starch solution and mixed. Subsequently, when a few drops of iodine solution were added to it once every five minutes, the resulting colors were observed as shown in the table below.

| Time (min.) | 5    | 10   | 15   | 20    | 25    |
|-------------|------|------|------|-------|-------|
| colour      | Blue | Blue | Blue | Brown | ..... |

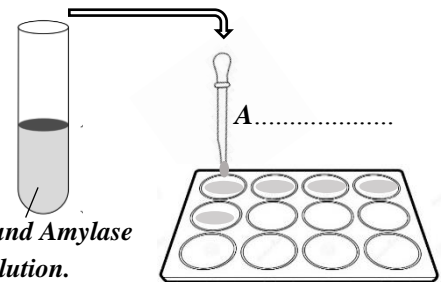

- Write the color corresponding to 25 minutes in the blank space of the table. (01)
- Name the apparatus labeled as A shown in the diagram. (01)
- State reasons for the following observations:
  - The presence of a blue color at 10 minutes:.....(01)
  - The occurrence of a brown color at 20 minutes:.....(01)
- What is the new compound formed in the solution after 20 minutes? .....(01)
- What is the catalyst used in the above activity?.....(01)

3. (A) Shown below as P, Q and R are the structural formulas of three hydrocarbons.

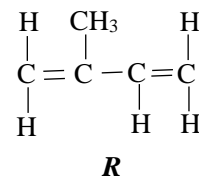
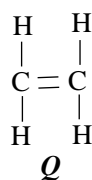
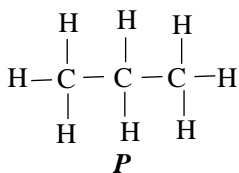

- Select the hydrocarbon relevant to each characteristic shown in the table and indicate it using the letters P, Q, and R.

| Characteristic                      | Hydrocarbon/s |
|-------------------------------------|---------------|
| (a) Belongs to the Alkene group.    |               |
| (b) A constituent of L.P. Gas.      |               |
| (c) A monomer of a natural polymer. |               |



- (ii) (a) The incomplete equation for the complete combustion of **P** is shown below. State the suitable values for **X** and **Y**.

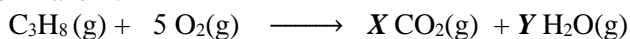

**X** ..... **Y** .....

(01)

- (b) Complete the Lewis structure of the carbon dioxide molecule, which is obtained as a gaseous product, inside the box.

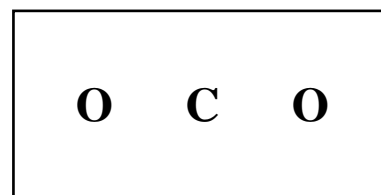

(01)

- (B) The graphical representation shows the variation of the first ionization energy of successive elements in the third period of the periodic table.

- (i) Which element among the given elements has the maximum first ionization energy?.....(01)
- (ii) Write the symbols of the relevant elements in the blanks (a) and (b) of the graph. (02)
- (iii) Select the most suitable position from **X**, **Y**, and **Z** to include the element Potassium (K) in this graphical representation, and complete the graph by connecting that position with Argon (Ar). (01)

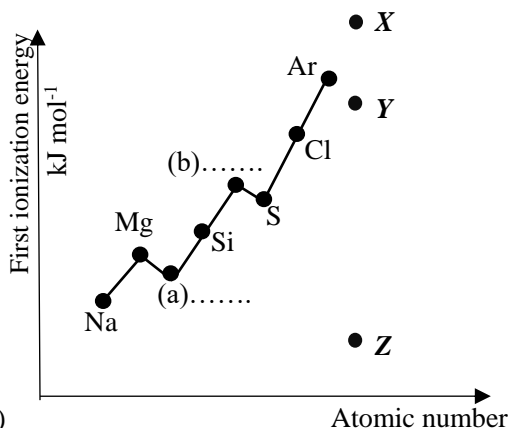

- (iv) Among the elements given in the graph:
- (a) Which element has the highest electronegativity? ..... (01)
- (b) Which element is a metalloid?..... (01)
- (v) Write the electron configuration of the Magnesium atom. ....(01)
- (vi) One of these elements reacts rapidly with water to form a basic solution and a gas.
- (a) What is that element?.....(01)
- (b) Name the chemical substance used to identify that a basic solution has been formed.....(01)
- (c) What color does that chemical substance give with a basic solution?.....(01)

- 4.(A) The image shows a wooden block of mass 100 g placed on a rough surface.

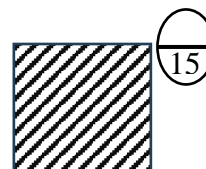

- (i) What is the weight of the wooden block?.....(01)
- (ii) Mark (✓) for the following instances if a frictional force acts on the wooden block, and mark (✗) if it does not. (05)

| Instance   | (✓)/(✗) |
|--|---------|
| (a) No horizontal forces act on the object. The object remains at rest.  |         |
| (b) A small horizontal force acts on the object. The object remains at rest.   |         |
| (c) Powder is applied between the block and the surface and a horizontal force is applied. The object just begins to move. |         |
| (d) External forces acting on the object are balanced. The object moves with a uniform velocity.                           |         |
| (e) A force is applied vertically upwards on the block. The object does not move.  |         |

- (iii) A wooden block initially at rest is pulled forward on a surface for a duration of 3 s by applying a horizontal force of 0.5 N. At this instance, the frictional force exerted on the object by the horizontal surface is 0.1 N.

- (a) What is the unbalanced force acting on the wooden block? (01)
- .....

(b) Calculate the acceleration of the object during this instance.

.....  
 .....

(c) Draw a labeled velocity-time graph for the motion of the object.

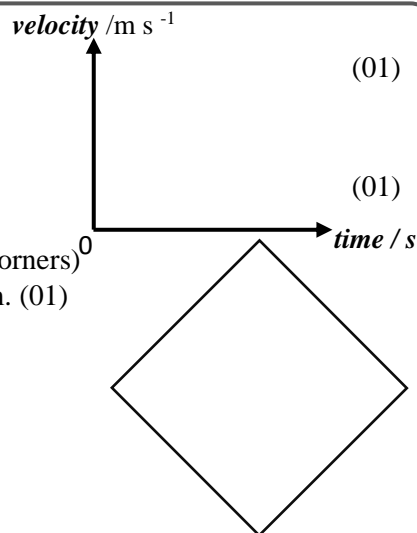

(01)

(01)

(iv) If the cube-shaped object is momentarily balanced on one of its vertices (corners) as shown in the figure, mark the forces acting on the object in the diagram. (01)

(B) The figures 1, 2, and 3 show three steps of an activity conducted by a group of students.

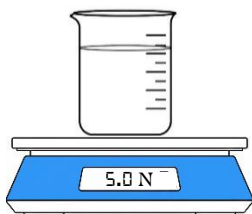
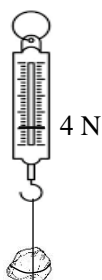

Figure 1

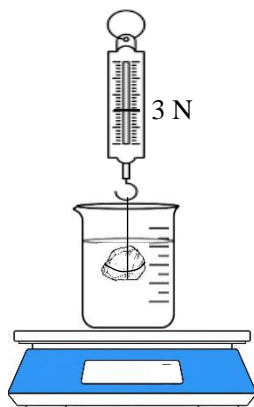

Figure 2

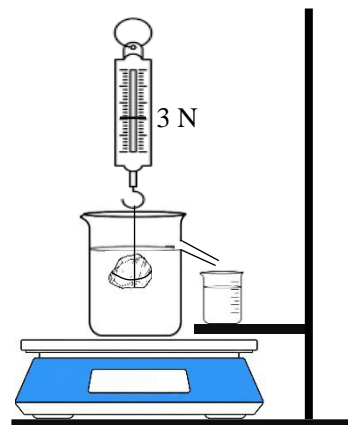

Figure 3

- (i) What is the upthrust exerted by the water on the stone? ..... (01)
- (ii) What is the reading on the table scale in the instance shown in Figure 2?.....(02)
- (iii) If the stone was immersed in an overflow can completely filled with water instead of a regular beaker, what would the reading on the table scale be? ..... (02)

\*\*\*

**Part B**

5. (A) A flow chart used to represent how the excess tissue fluid collecting in the intercellular spaces connects to the blood circulatory system is shown below.

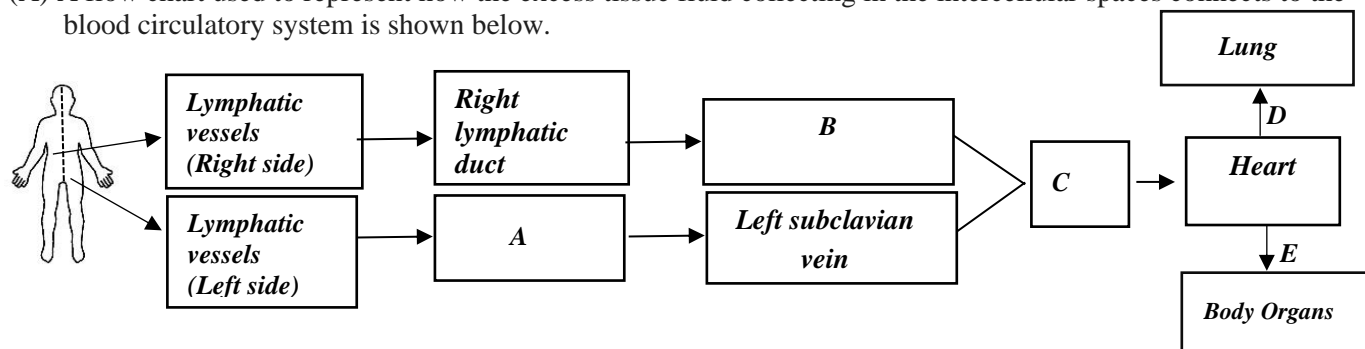

- (i) Name the structures **A**, **B** and **C** in the above flow chart. (03)
- (ii) To which chamber of the heart does vessel **C** open? (01)
- (iii) What is the type of blood cell present in the left subclavian vein but not present in the lymphatic duct **A**? (01)
- (iv) Mention a type of digestive end-product that is added to the lymph from the small intestine during the absorption of digestive products. (01)
- (iv) What is the difference in blood composition between arteries **D** and **E** connected to the heart? (01)

(B) Among the athletes engaged in a 100 m sprint at a sports meet, one athlete won the race by increasing his speed at the final moment.

- (i) What was the most active muscle type in the runner's body while running at maximum speed? (01)
- (ii) What is the specialty present in the muscle cells mentioned in (i) above, which is important for obtaining the necessary power through cellular respiration? (01)
- (iv) If the athlete experienced a muscle cramp in the leg after running, what is the biological process occurring in the muscle cells that could cause it? (01)
- (iv) What is the biochemical compound contained within cells that contributes to releasing energy? (01)
- (v) Name a system whose activity may increase to provide the necessary nutrients to muscle cells during running. (01)
- (vi) While engaged in the race, the athlete's heart rate and lung aeration rate increase. Which subsystem of the autonomic nervous system contributes to this? (01)
- (vii) What is the hormone that prepares the body for an emergency situation? (01)
- (viii) The coach says that engaging in a sudden sprint without proper training can even lead to fatal conditions. What could be the reason for this? (01)

(C) Three types of plants in a garden are labeled as **A**, **B**, and **C** in the figure. A rough diagram prepared on how their seeds were dispersed after examining the seed dispersal of plants **A** and **B** is shown in the figure. Plant **C** has not produced seeds.

- (i) Estimate and mention separately the most likely dispersal methods for the seeds of plants **A** and **B**. (02)
- (ii) Briefly explain how you predicted the seed dispersal method of plant **B**. (01)
- (iii) Briefly explain which plant is more suitable for a cultivation expected to be carried out in an area with a dry climate. (01)
- (v) Mention a special adaptation found in plants where seed dispersal occurs by wind. (01)

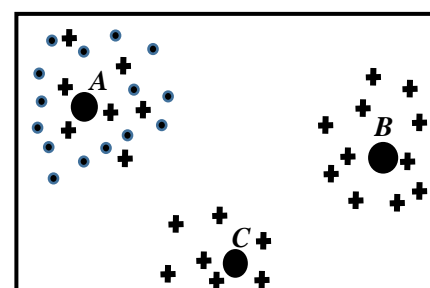

■ = seeds of plant A,  
+ = seeds of plant B (20 marks)

6. (A) The saltern method is used for salt extraction in Sri Lanka. In this, three types of tanks are used as shown in the figure.

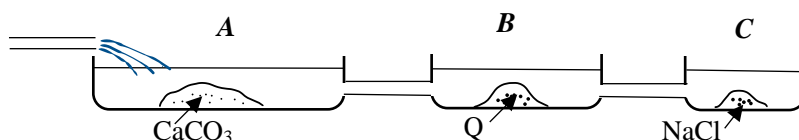

- (i) What is the reason for  $\text{CaCO}_3$  precipitating in the first tank? (02)
- (ii) Name substance **Q** that precipitates in tank **B**. (01)

- (iii) State an advantage of constructing tank A with less depth and greater length and width. (01)
- (iv) Name two separation techniques used in the salt extraction process in Sri Lanka. (02)
- (v) It was found that a salt sample purchased from a shop contains water-soluble and insoluble impurities. Show the procedure to be followed in three steps to remove those impurities and obtain a pure salt sample. (03)

(vi) Why should iodized salt be kept in a place where sunlight does not fall? (01)

(B) An apparatus setup prepared by a group of students to produce hydrogen gas using magnesium and dilute hydrochloric acid is shown in the figure below.

(i) Name the instruments A and B in the setup. (02)

(ii) A student says there is a defect in the above setup. (02)

(a) What is the defect?

(b) What is the disadvantage / error caused by the defect?

(iii) Write a strategy to be followed here to collect a gas sample of higher purity.

(iv) Mention two strategies that can be done to increase the rate of reaction. (02)

(v) If 4.8 g of magnesium ribbons were used for the activity, calculate the number of moles of magnesium contained in it. ( $M_g = 24$ ) (02)

(vi) Draw a rough sketch of the graph between the mass of magnesium consumed and time in this activity. (02)

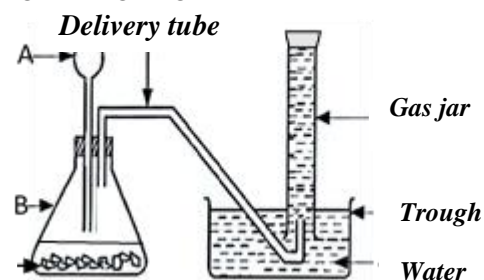

( 20 marks)

7. (A) An immersion heater with a resistance of  $48 \Omega$  is immersed in 1.5 kg of water and connected to a 240 V electricity supply.

(i) When the immersion heater operates at maximum efficiency,

(a) Write the energy transformation that occurs. (01)

(b) How much current flows through the immersion heater? (01)

(c) Calculate the amount of heat energy released to the water in 2 s. (01)

(ii) Find the time taken to increase the temperature of the water container by  $40^\circ\text{C}$ .

(Specific heat capacity of water =  $4200 \text{ J kg}^{-1}\text{ }^\circ\text{C}^{-1}$ ) (02)

(iii) A student says that to heat the water more quickly and uniformly, the immersion heater should be immersed as deep as possible in the water. Explain the reason for this. (01)

(iv) A diagram of a three-pin plug to which the immersion heater is connected is shown below.

(a) Identify the electrical wires A and B connected to the three-pin plug. (02)

(b) Explain the importance of connecting an earth wire to the plug connected to the immersion heater. (01)

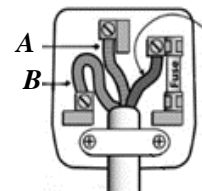

(B) A motor car with a mass of 1500 kg travels at a uniform velocity of  $20 \text{ m s}^{-1}$  on a straight road. To stop the car near a shop ahead, the driver applies brakes and moves with uniform retardation for a period of 8 s to come to rest.

(i) Draw the velocity-time graph for the period from the moment the driver applied the brakes until it comes to rest. (02)

(ii) Calculate the following information based on the graph.

(a) The retardation of the car. (02)

(b) The distance traveled during retardation. (02)

(iii) What was the unbalanced force acting on the car when it traveled with retardation? (02)

(iv) Which of Newton's laws can be used to explain the change in motion of the motor car when brakes are applied? (01)

(v) Calculate the momentum of the motor car when it was traveling at a uniform velocity. (02)

( 20 marks)

8. (A) Several steps of an activity carried out in the school laboratory to identify cells in an onion peel are shown by figures P, Q, R, and S.

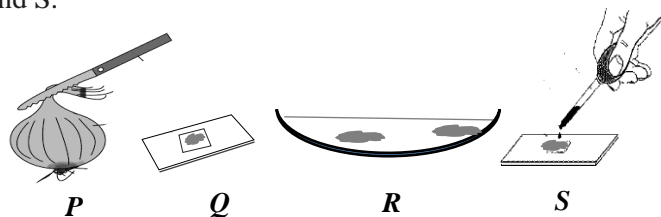

- (i) Show the correct sequence in which the activity should be done using the given English letters. (01)
- (ii) What is the reason for placing the specimen on the glass slide and adding a little water? (01)
- (iii) Mention an organelle that is observed when the prepared slide is observed through a light microscope. (01)
- (iv) What is the main function of the organelle you mentioned? (01)
- (v) Write an organelle and a structure respectively that are contained in an onion peel cell but not in an animal cell. (02)

(B) Hemophilia, Thalassemia, and red-green color blindness are several genetic disorders.

- (i) Classify them as genetic disorders caused by sex-linked inheritance and gene mutations. (02)
- (ii) In the carrier state, the genetic disorder is not expressed in the individual. Explain the reason for this using the genotype. (01)
- (iii) There are male carriers for Thalassemia, but there are no male carriers for Hemophilia. Explain simply. (01)

(C) The figure shows how a wave is created by moving the free end of a rope, which is firmly connected to a wall at one end, vertically up and down. (Consider that the waves created here are not reflected back from the wall)

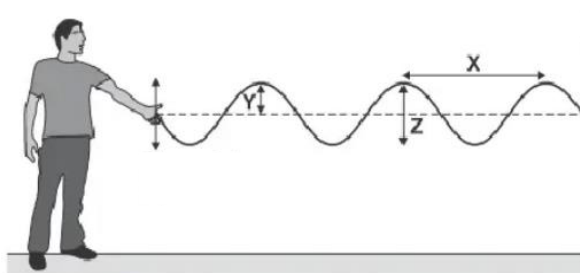

- (i) Does energy transmission by the wave occur perpendicular or parallel to the direction in which the medium particles vibrate? (01)
- (ii) Two unique measurements of the wave are represented by the letters X and Y. Name them respectively. (01)
- (iii) Write the relationship between the direction the wave travels and the direction the particles of the medium vibrate. (01)
- (iv) When the open end of the rope is moved vertically up and down, three vibrations are created in one second. If the length of X is 1.2 m, study the given diagram and state the following information numerically.
  - (a) Frequency of the wave. (02)
  - (b) Speed of the wave. (02)

(D) An object is placed in front of a concave mirror with a focal length of 20 cm.

The nature of the image changes as the object is gradually brought towards the concave mirror.

- (i) State the relationship between the height of the object and the height of the image when an object is placed 30 cm in front of the concave mirror. (01)
- (ii) Show the formation of the image when an object is placed 10 cm in front of the mirror using a ray diagram. (02)

( 20 marks)

9. (A) A diagram of an electrolytic cell prepared by a group of students is shown here.

(i) Write a suitable solution that can be used for the solution used as X. (01)

(ii) Write another observation that can be seen when the setup is operating, other than the deposition of the reddish-brown layer. (01)

(iii) Write the half-reaction occurring near the anode. (02)

(iv) (a) A student says that the solution becomes acidic at the end of electrolysis. What is the reason for that? (01)

(b) Mention how you would confirm that the solution has become acidic. (01)

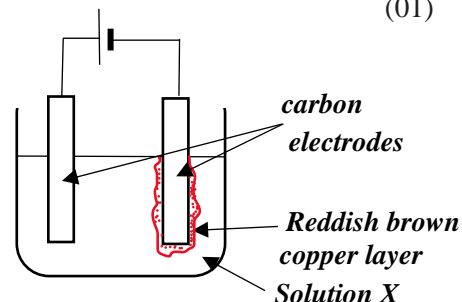

(B) In an experiment conducted to calculate the heat change of the reaction between NaOH and HCl, 50 ml of 1 mol dm<sup>-3</sup> NaOH solution and 50 ml of 1 mol dm<sup>-3</sup> HCl were taken, their initial temperatures were measured, and the maximum temperature of the mixture was measured after mixing the two solutions.

(i) According to the heat change, to which type does this reaction belong? (01)

(ii) If the temperatures of the two solutions are unequal to each other, what value is taken as the initial temperature? (01)

(iii) Other than the temperature difference, what other values should be obtained for this calculation? (01)

(iv) The teacher says that the value obtained by calculating the heat change in this experiment is not the most accurate value. What could be the reason for that? (01)

(C) A circuit diagram of an electrical converter (inverter) prepared to obtain a 240 V alternating current (AC) from a 12 V direct current (DC) is shown in the figure. An oscillator that emits fifty very small electrical pulses in one second, a transformer (TR-1), and an LED panel are connected to this.

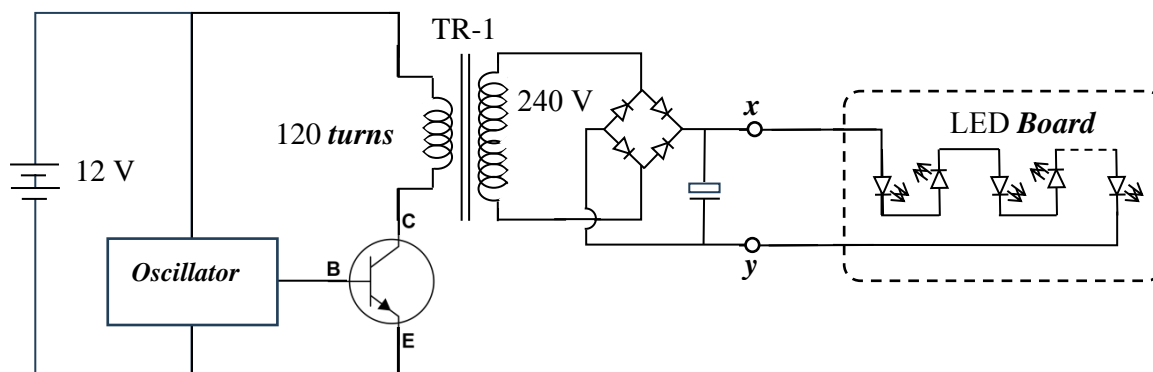

(i) The transistor used in this circuit,  
 (a) What type of transistor is it? (01)  
 (b) What is the function performed by it? (01)

(ii) It is stated in the specifications that a 240 V supply can be obtained from the secondary coil when a 12 V supply is given to the primary coil of TR-1.  
 (a) What is the number of turns contained in the secondary coil? (02)  
 (b) If the current flowing through the primary coil is 1 A, what is the current flowing through the secondary coil? (02)

(iii) An LED panel is fixed to terminals x and y as shown in the figure.  
 (a) Are the LEDs in the panel connected in series or in parallel? (01)  
 (b) Find the resistance across the two ends of the LED panel. (02)

(iv) If a cathode ray oscilloscope (CRO) was connected to terminals x and y, draw the wave diagram expected to be recorded on it. (01)

( 20 marks)